

Single Garage
 Plots - 1, 2, 3, 4, 5, 25, 45, 59, 67, 70, 74,
 86, 98, 103, 112, 118, 120, 123, 129, 140,
 141, 149, 150, 155, 156, 157, 158, 161, 193,
 196, 201, 211, 214

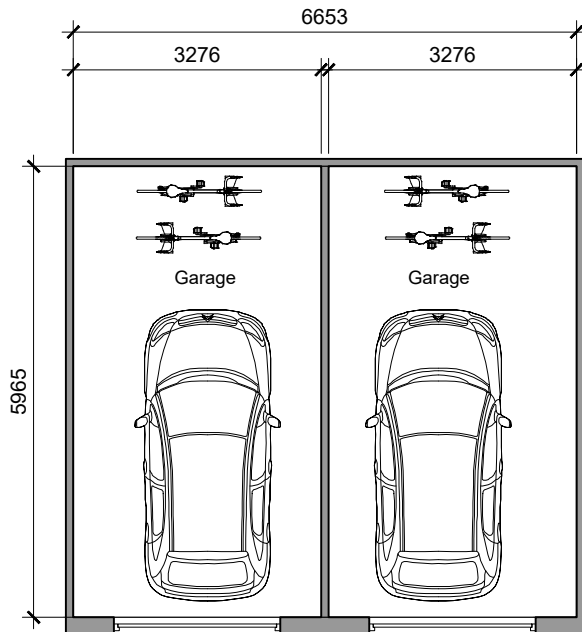

Double Garage
 Plots - 8, 9, 31, 32, 39, 40, 41, 42, 89, 90,
 93, 94, 104, 105, 108, 109, 114, 115, 116,
 117, 121, 122, 156, 157, 160, 161, 192, 199,
 200, 202, 203, 210, 212, 213



Front Elevation
 Plots - 1, 2, 3, 4, 5, 25, 45, 59,
 67, 70, 74, 86, 98, 103, 112,
 118, 120, 123, 129, 140, 141,
 149, 150, 155, 156, 157, 158,
 161, 193, 196, 201, 211, 214

Side Elevation

Side Elevation

Side Elevation



Front Elevation
 Plots - 8, 9, 31, 32, 39, 40, 41, 42, 89, 90,
 93, 94, 104, 105, 108, 109, 114, 115, 116,
 117, 121, 122, 156, 157, 160, 161, 192, 199,
 200, 202, 203, 210, 212, 213

Side Elevation

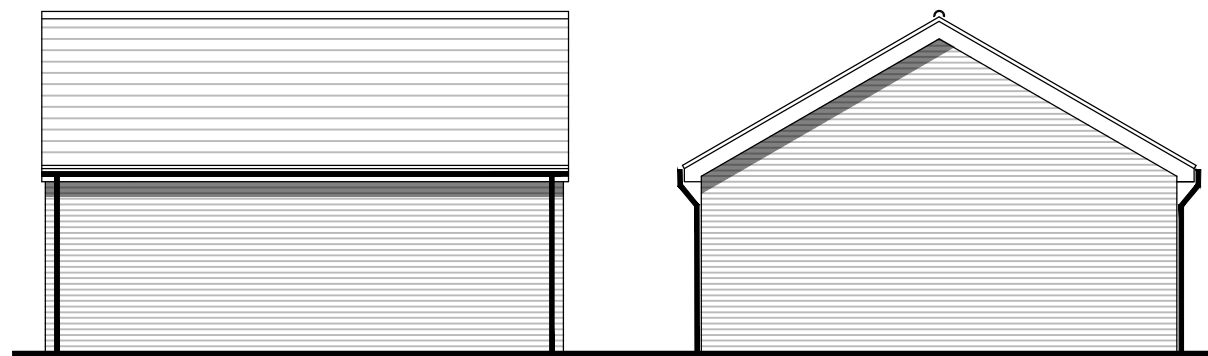

Rear Elevation

Side Elevation

Client's Name
Vistry Group

Job Title
**Reading Golf Club
 Kidmore End Road, Reading**

Drawing Title
**Garages - Proposed Plans and
 Elevations**

Scale
1:100 @ A3

Drawn	Checked	Date
LP	MP	20.05.2022
Job No	Drawing No	Rev
6960	PL154	B
Status	APPROVAL	

Rev	Date	Revision Details	Dr	Ch
B	23.08.22	Amended to DRP comments	LP	MP
A	10.06.22	House types Amended to Clients Comments	LP	MP

London: 76 Great Suffolk Street, London, SE1 0BL
 T 0207 928 2773 E london@ecearchitecture.com
 Sussex: 64 - 68 Brighton Road, Worthing West Sussex, BN11 2EN
 T 01903 248777 E sussex@ecearchitecture.com
 Bristol: Westworks, Beacon Tower Colston Street, Bristol, BS1 4XE
 T 0117 214 1101 E bristol@ecwestworks.com
ECE Architecture
 www.ecearchitecture.com